



*An Online CPD Course
brought to you by
CEDengineering.ca*

Heat Transfer

Course No: M03-001

Credit: 3 PDH

Elie Tawil, P.E., LEED AP



Continuing Education and Development, Inc.

P: (877) 322-5800

info@cedengineering.ca

This course was adapted from the Department of Energy, Publication No. DOE-HDBK-1012/1-92, "Thermodynamics, Heat Transfer and Fluid Flow", which is in the public domain.

TABLE OF CONTENTS

LIST OF FIGURES	iii
LIST OF TABLES	iv
REFERENCES	v
OBJECTIVES	vii
HEAT TRANSFER TERMINOLOGY	1
Heat and Temperature	1
Heat and Work	2
Modes of Transferring Heat	2
Heat Flux	3
Thermal Conductivity	3
Log Mean Temperature Difference	3
Convective Heat Transfer Coefficient	4
Overall Heat Transfer Coefficient	4
Bulk Temperature	4
Summary	5
CONDUCTION HEAT TRANSFER	6
Conduction	6
Conduction-Rectangular Coordinates	7
Equivalent Resistance Method	9
Electrical Analogy	10
Conduction-Cylindrical Coordinates	11
Summary	17
CONVECTION HEAT TRANSFER	18
Convection	18
Overall Heat Transfer Coefficient	20
Convection Heat Transfer	23
Summary	25
RADIANT HEAT TRANSFER	26
Thermal Radiation	26
Black Body Radiation	26
Emissivity	27

TABLE OF CONTENTS (Cont.)

Radiation Configuration Factor	27
Summary	29
HEAT EXCHANGERS	30
Heat Exchangers	30
Parallel and Counter-Flow Designs	31
Non-Regenerative Heat Exchanger	34
Regenerative Heat Exchanger	34
Cooling Towers	35
Log Mean Temperature Difference Application to Heat Exchangers	36
Overall Heat Transfer Coefficient	37
Summary	39
BOILING HEAT TRANSFER	40
Boiling	40
Nucleate Boiling	40
Bulk Boiling	41
Film Boiling	41
Departure from Nucleate Boiling and Critical Heat Flux	42
Summary	43
HEAT GENERATION	44
Heat Generation	44
Flux Profiles	46
Thermal Limits	47
Average Linear Power Density	47
Maximum Local Linear Power Density	48
Temperature Profiles	48
Volumetric Thermal Source Strength	50
Fuel Changes During Reactor Operation	50
Summary	51
DECAY HEAT	52
Reactor Decay Heat Production	52
Calculation of Decay heat	53
Decay Heat Limits	55
Decay Heat Removal	56
Summary	57

LIST OF FIGURES

Figure 1	Conduction Through a Slab	7
Figure 2	Equivalent Resistance	10
Figure 3	Cross-sectional Surface Area of a Cylindrical Pipe	11
Figure 4	Composite Cylindrical Layers	15
Figure 5	Pipe Insulation Problem	16
Figure 6	Overall Heat Transfer Coefficient	20
Figure 7	Combined Heat Transfer	21
Figure 8	Typical Tube and Shell Heat Exchanger	31
Figure 9	Fluid Flow Direction	32
Figure 10	Heat Exchanger Temperature Profiles	33
Figure 11	Non-Regenerative Heat Exchanger	34
Figure 12	Regenerative Heat Exchanger	35
Figure 13	Boiling Heat Transfer Curve	42
Figure 14	Axial Flux Profile	46
Figure 15	Radial Flux Profile	46
Figure 16	Axial Temperature Profile	48
Figure 17	Radial Temperature Profile Across a Fuel Rod and Coolant Channel	49

LIST OF TABLES

NONE

REFERENCES

- VanWylen, G. J. and Sonntag, R. E., Fundamentals of Classical Thermodynamics SI Version, 2nd Edition, John Wiley and Sons, New York, ISBN 0-471-04188-2.
- Kreith, Frank, Principles of Heat Transfer, 3rd Edition, Intext Press, Inc., New York, ISBN 0-7002-2422-X.
- Holman, J. P., Thermodynamics, McGraw-Hill, New York.
- Streeter, Victor, L., Fluid Mechanics, 5th Edition, McGraw-Hill, New York, ISBN 07-062191-9.
- Rynolds, W. C. and Perkins, H. C., Engineering Thermodynamics, 2nd Edition, McGraw-Hill, New York, ISBN 0-07-052046-1.
- Meriam, J. L., Engineering Mechanics Statics and Dynamics, John Wiley and Sons, New York, ISBN 0-471-01979-8.
- Schneider, P. J. Conduction Heat Transfer, Addison-Wesley Pub. Co., California.
- Holman, J. P., Heat Transfer, 3rd Edition, McGraw-Hill, New York.
- Knudsen, J. G. and Katz, D. L., Fluid Dynamics and Heat Transfer, McGraw-Hill, New York.
- Kays, W. and London, A. L., Compact Heat Exchangers, 2nd Edition, McGraw-Hill, New York.
- Weibelt, J. A., Engineering Radiation Heat Transfer, Holt, Rinehart and Winston Publish., New York.
- Sparrow, E. M. and Cess, R. E., Radiation Heat Transfer, Brooks/Cole Publish. Co., Belmont, California.
- Hamilton, D. C. and Morgan, N. R., Radiant-Interchange Configuration Factors, Tech. Note 2836, National Advisory Committee for Aeronautics.
- McDonald, A. T. and Fox, R. W., Introduction to Fluid mechanics, 2nd Edition, John Wiley and Sons, New York, ISBN 0-471-01909-7.

REFERENCES (Cont.)

- Zucrow, M. J. and Hoffman, J. D., Gas Dynamics Vol.b1, John Wiley and Sons, New York, ISBN 0-471-98440-X.
- Crane Company, Flow of Fluids Through Valves, Fittings, and Pipe, Crane Co. Technical Paper No. 410, Chicago, Illinois, 1957.
- Esposito, Anthony, Fluid Power with Applications, Prentice-Hall, Inc., New Jersey, ISBN 0-13-322701-4.
- Beckwith, T. G. and Buck, N. L., Mechanical Measurements, Addison-Wesley Publish Co., California.
- Wallis, Graham, One-Dimensional Two-Phase Flow, McGraw-Hill, New York, 1969.
- Kays, W. and Crawford, M. E., Convective Heat and Mass Transfer, McGraw-Hill, New York, ISBN 0-07-03345-9.
- Collier, J. G., Convective Boiling and Condensation, McGraw-Hill, New York, ISBN 07-084402-X.
- Academic Program for Nuclear Power Plant Personnel, Volumes III and IV, Columbia, MD: General Physics Corporation, Library of Congress Card #A 326517, 1982.
- Faires, Virgel Moring and Simmang, Clifford Max, Thermodynamics, MacMillan Publishing Co. Inc., New York.

TERMINAL OBJECTIVE

- 1.0 Given the operating conditions of a thermodynamic system and the necessary formulas, **EVALUATE** the heat transfer processes which are occurring.

ENABLING OBJECTIVES

- 1.1 **DESCRIBE** the difference between heat and temperature.
- 1.2 **DESCRIBE** the difference between heat and work.
- 1.3 **DESCRIBE** the Second Law of Thermodynamics and how it relates to heat transfer.
- 1.4 **DESCRIBE** the three modes of heat transfer.
- 1.5 **DEFINE** the following terms as they relate to heat transfer:
- a. Heat flux
 - b. Thermal conductivity
 - c. Log mean temperature difference
 - d. Convective heat transfer coefficient
 - e. Overall heat transfer coefficient
 - f. Bulk temperature
- 1.6 Given Fourier's Law of Conduction, **CALCULATE** the conduction heat flux in a rectangular coordinate system.
- 1.7 Given the formula and the necessary values, **CALCULATE** the equivalent thermal resistance.
- 1.8 Given Fourier's Law of Conduction, **CALCULATE** the conduction heat flux in a cylindrical coordinate system.
- 1.9 Given the formula for heat transfer and the operating conditions of the system, **CALCULATE** the rate of heat transfer by convection.
- 1.10 **DESCRIBE** how the following terms relate to radiant heat transfer:
- a. Black body radiation
 - b. Emissivity
 - c. Radiation configuration factor

ENABLING OBJECTIVES (Cont.)

- 1.11 **DESCRIBE** the difference in the temperature profiles for counter-flow and parallel flow heat exchangers.
- 1.12 **DESCRIBE** the differences between regenerative and non-regenerative heat exchangers.
- 1.13 Given the temperature changes across a heat exchanger, **CALCULATE** the log mean temperature difference for the heat exchanger.
- 1.14 Given the formulas for calculating the conduction and convection heat transfer coefficients, **CALCULATE** the overall heat transfer coefficient of a system.
- 1.15 **DESCRIBE** the process that occurs in the following regions of the boiling heat transfer curve:
 - a. Nucleate boiling
 - b. Partial film boiling
 - c. Film boiling
 - d. Departure from nucleate boiling (DNB)
 - e. Critical heat flux

TERMINAL OBJECTIVE

- 2.0 Given the operating conditions of a typical nuclear reactor, **DESCRIBE** the heat transfer processes which are occurring.

ENABLING OBJECTIVES

- 2.1 **DESCRIBE** the power generation process in a nuclear reactor core and the factors that affect the power generation.
- 2.2 **DESCRIBE** the relationship between temperature, flow, and power during operation of a nuclear reactor.
- 2.3 **DEFINE** the following terms:
- a. Nuclear enthalpy rise hot channel factor
 - b. Average linear power density
 - c. Nuclear heat flux hot channel factor
 - d. Heat generation rate of a core
 - e. Volumetric thermal source strength
- 2.4 **CALCULATE** the average linear power density for an average reactor core fuel rod.
- 2.5 **DESCRIBE** a typical reactor core axial and radial flux profile.
- 2.6 **DESCRIBE** a typical reactor core fuel rod axial and radial temperature profile.
- 2.7 **DEFINE** the term decay heat.
- 2.8 Given the operating conditions of a reactor core and the necessary formulas, **CALCULATE** the core decay heat generation.
- 2.9 **DESCRIBE** two categories of methods for removing decay heat from a reactor core.

HEAT TRANSFER TERMINOLOGY

To understand and communicate in the thermal science field, certain terms and expressions must be learned in heat transfer.

- EO 1.1** **DESCRIBE the difference between heat and temperature.**
- EO 1.2** **DESCRIBE the difference between heat and work.**
- EO 1.3** **DESCRIBE the Second Law of Thermodynamics and how it relates to heat transfer.**
- EO 1.4** **DESCRIBE the three modes of heat transfer.**
- EO 1.5** **DEFINE the following terms as they relate to heat transfer:**
- a.** **Heat flux**
 - b.** **Thermal conductivity**
 - c.** **Log mean temperature difference**
 - d.** **Convective heat transfer coefficient**
 - e.** **Overall heat transfer coefficient**
 - f.** **Bulk temperature**

Heat and Temperature

In describing heat transfer problems, students often make the mistake of interchangeably using the terms heat and temperature. Actually, there is a distinct difference between the two. *Temperature* is a measure of the amount of energy possessed by the molecules of a substance. It is a relative measure of how hot or cold a substance is and can be used to predict the direction of heat transfer. The symbol for temperature is T. The common scales for measuring temperature are the Fahrenheit, Rankine, Celsius, and Kelvin temperature scales.

Heat is energy in transit. The transfer of energy as heat occurs at the molecular level as a result of a temperature difference. Heat is capable of being transmitted through solids and fluids by conduction, through fluids by convection, and through empty space by radiation. The symbol for heat is Q. Common units for measuring heat are the British Thermal Unit (Btu) in the English system of units and the calorie in the SI system (International System of Units).

Heat and Work

Distinction should also be made between the energy terms *heat* and *work*. Both represent energy in transition. Work is the transfer of energy resulting from a force acting through a distance. Heat is energy transferred as the result of a temperature difference. Neither heat nor work are thermodynamic properties of a system. Heat can be transferred into or out of a system and work can be done on or by a system, but a system cannot contain or store either heat or work. Heat into a system and work out of a system are considered positive quantities.

When a temperature difference exists across a boundary, the Second Law of Thermodynamics indicates the natural flow of energy is from the hotter body to the colder body. The Second Law of Thermodynamics denies the possibility of ever completely converting into work all the heat supplied to a system operating in a cycle. The Second Law of Thermodynamics, described by Max Planck in 1903, states that:

It is impossible to construct an engine that will work in a complete cycle and produce no other effect except the raising of a weight and the cooling of a reservoir.

The second law says that if you draw heat from a reservoir to raise a weight, lowering the weight will not generate enough heat to return the reservoir to its original temperature, and eventually the cycle will stop. If two blocks of metal at different temperatures are thermally insulated from their surroundings and are brought into contact with each other the heat will flow from the hotter to the colder. Eventually the two blocks will reach the same temperature, and heat transfer will cease. Energy has not been lost, but instead some energy has been transferred from one block to another.

Modes of Transferring Heat

Heat is always transferred when a temperature difference exists between two bodies. There are three basic modes of heat transfer:

Conduction involves the transfer of heat by the interactions of atoms or molecules of a material through which the heat is being transferred.

Convection involves the transfer of heat by the mixing and motion of macroscopic portions of a fluid.

Radiation, or radiant heat transfer, involves the transfer of heat by electromagnetic radiation that arises due to the temperature of a body.

The three modes of heat transfer will be discussed in greater detail in the subsequent chapters of this module.

Heat Flux

The rate at which heat is transferred is represented by the symbol \dot{Q} . Common units for heat transfer rate is Btu/hr. Sometimes it is important to determine the heat transfer rate per unit area, or *heat flux*, which has the symbol \dot{Q}'' . Units for heat flux are Btu/hr-ft². The heat flux can be determined by dividing the heat transfer rate by the area through which the heat is being transferred.

$$\dot{Q}'' = \frac{\dot{Q}}{A} \quad (2-1)$$

where:

\dot{Q}'' = heat flux (Btu/hr-ft²)

\dot{Q} = heat transfer rate (Btu/hr)

A = area (ft²)

Thermal Conductivity

The heat transfer characteristics of a solid material are measured by a property called the *thermal conductivity* (k) measured in Btu/hr-ft-°F. It is a measure of a substance's ability to transfer heat through a solid by conduction. The thermal conductivity of most liquids and solids varies with temperature. For vapors, it depends upon pressure.

Log Mean Temperature Difference

In heat exchanger applications, the inlet and outlet temperatures are commonly specified based on the fluid in the tubes. The temperature change that takes place across the heat exchanger from the entrance to the exit is not linear. A precise temperature change between two fluids across the heat exchanger is best represented by the *log mean temperature difference* (LMTD or ΔT_{lm}), defined in Equation 2-2.

$$\Delta T_{lm} = \frac{(\Delta T_2 - \Delta T_1)}{\ln(\Delta T_2/\Delta T_1)} \quad (2-2)$$

where:

ΔT_2 = the larger temperature difference between the two fluid streams at either the entrance or the exit to the heat exchanger

ΔT_1 = the smaller temperature difference between the two fluid streams at either the entrance or the exit to the heat exchanger

Convective Heat Transfer Coefficient

The convective heat transfer coefficient (h), defines, in part, the heat transfer due to convection. The *convective heat transfer coefficient* is sometimes referred to as a film coefficient and represents the thermal resistance of a relatively stagnant layer of fluid between a heat transfer surface and the fluid medium. Common units used to measure the convective heat transfer coefficient are Btu/hr - ft² - °F.

Overall Heat Transfer Coefficient

In the case of combined heat transfer, it is common practice to relate the total rate of heat transfer (\dot{Q}), the overall cross-sectional area for heat transfer (A_o), and the overall temperature difference (ΔT_o) using the overall heat transfer coefficient (U_o). The *overall heat transfer coefficient* combines the heat transfer coefficient of the two heat exchanger fluids and the thermal conductivity of the heat exchanger tubes. U_o is specific to the heat exchanger and the fluids that are used in the heat exchanger.

$$\dot{Q} = U_o A_o \Delta T_o \quad (2-3)$$

where:

\dot{Q} = the rate heat of transfer (Btu/hr)

U_o = the overall heat transfer coefficient (Btu/hr - ft² - °F)

A_o = the overall cross-sectional area for heat transfer (ft²)

ΔT_o = the overall temperature difference (°F)

Bulk Temperature

The fluid temperature (T_b), referred to as the *bulk temperature*, varies according to the details of the situation. For flow adjacent to a hot or cold surface, T_b is the temperature of the fluid that is "far" from the surface, for instance, the center of the flow channel. For boiling or condensation, T_b is equal to the saturation temperature.

Summary

The important information in this chapter is summarized below.

Heat Transfer Terminology Summary

- Heat is energy transferred as a result of a temperature difference.
- Temperature is a measure of the amount of molecular energy contained in a substance.
- Work is a transfer of energy resulting from a force acting through a distance.
- The Second Law of Thermodynamics implies that heat will not transfer from a colder to a hotter body without some external source of energy.
- Conduction involves the transfer of heat by the interactions of atoms or molecules of a material through which the heat is being transferred.
- Convection involves the transfer of heat by the mixing and motion of macroscopic portions of a fluid.
- Radiation, or radiant heat transfer, involves the transfer of heat by electromagnetic radiation that arises due to the temperature of a body.
- Heat flux is the rate of heat transfer per unit area.
- Thermal conductivity is a measure of a substance's ability to transfer heat through itself.
- Log mean temperature difference is the ΔT that most accurately represents the ΔT for a heat exchanger.
- The local heat transfer coefficient represents a measure of the ability to transfer heat through a stagnant film layer.
- The overall heat transfer coefficient is the measure of the ability of a heat exchanger to transfer heat from one fluid to another.
- The bulk temperature is the temperature of the fluid that best represents the majority of the fluid which is not physically connected to the heat transfer site.

CONDUCTION HEAT TRANSFER

Conduction heat transfer is the transfer of thermal energy by interactions between adjacent atoms and molecules of a solid.

EO 1.6 **Given Fourier’s Law of Conduction, CALCULATE the conduction heat flux in a rectangular coordinate system.**

EO 1.7 **Given the formula and the necessary values, CALCULATE the equivalent thermal resistance.**

EO 1.8 **Given Fourier’s Law of Conduction, CALCULATE the conduction heat flux in a cylindrical coordinate system.**

Conduction

Conduction involves the transfer of heat by the interaction between adjacent molecules of a material. Heat transfer by conduction is dependent upon the driving "force" of temperature difference and the resistance to heat transfer. The resistance to heat transfer is dependent upon the nature and dimensions of the heat transfer medium. All heat transfer problems involve the temperature difference, the geometry, and the physical properties of the object being studied.

In conduction heat transfer problems, the object being studied is usually a solid. Convection problems involve a fluid medium. Radiation heat transfer problems involve either solid or fluid surfaces, separated by a gas, vapor, or vacuum. There are several ways to correlate the geometry, physical properties, and temperature difference of an object with the rate of heat transfer through the object. In conduction heat transfer, the most common means of correlation is through Fourier’s Law of Conduction. The law, in its equation form, is used most often in its rectangular or cylindrical form (pipes and cylinders), both of which are presented below.

$$\text{Rectangular} \quad \dot{Q} = k A \left(\frac{\Delta T}{\Delta x} \right) \quad (2-4)$$

$$\text{Cylindrical} \quad \dot{Q} = k A \left(\frac{\Delta T}{\Delta r} \right) \quad (2-5)$$

where:

- \dot{Q} = rate of heat transfer (Btu/hr)
- A = cross-sectional area of heat transfer (ft^2)
- Δx = thickness of slab (ft)
- Δr = thickness of cylindrical wall (ft)
- ΔT = temperature difference ($^{\circ}\text{F}$)
- k = thermal conductivity of slab (Btu/ft-hr- $^{\circ}\text{F}$)

The use of Equations 2-4 and 2-5 in determining the amount of heat transferred by conduction is demonstrated in the following examples.

Conduction-Rectangular Coordinates

Example:

1000 Btu/hr is conducted through a section of insulating material shown in Figure 1 that measures 1 ft^2 in cross-sectional area. The thickness is 1 in. and the thermal conductivity is $0.12 \text{ Btu/hr-ft-}^{\circ}\text{F}$. Compute the temperature difference across the material.

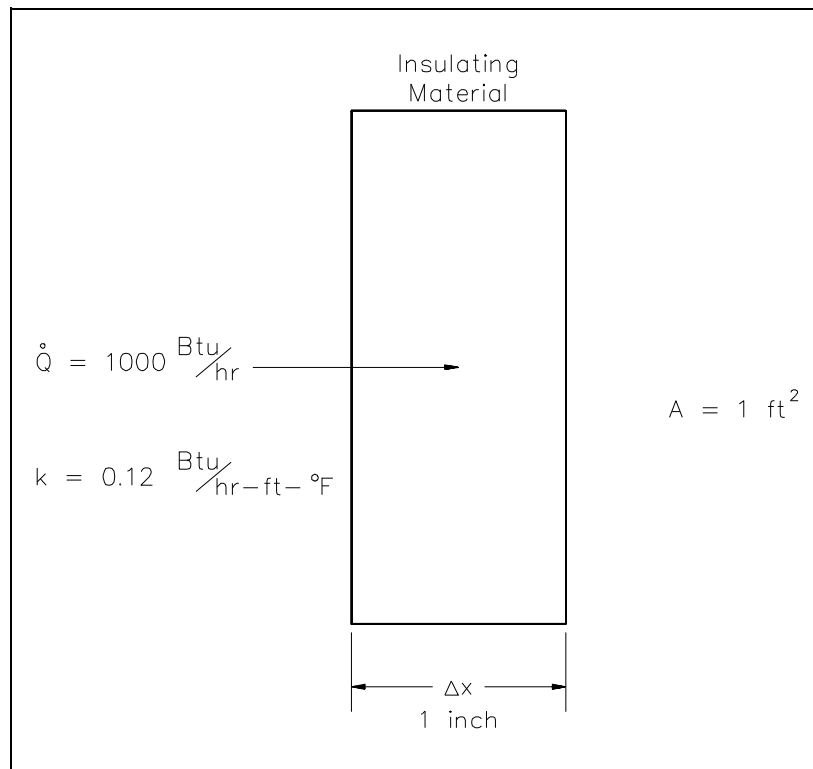

Figure 1 Conduction Through a Slab

Solution:

Using Equation 2-4:

$$\dot{Q} = k A \left(\frac{\Delta T}{\Delta x} \right)$$

Solving for ΔT :

$$\begin{aligned} \Delta T &= \dot{Q} \left(\frac{\Delta x}{k A} \right) \\ &= \frac{\left(1000 \frac{\text{Btu}}{\text{hr}} \right) \left(\frac{1}{12} \text{ ft} \right)}{\left(0.12 \frac{\text{Btu}}{\text{hr-ft-}^\circ\text{F}} \right) (1 \text{ ft}^2)} \end{aligned}$$

$$\Delta T = 694^\circ\text{F}$$

Example:

A concrete floor with a conductivity of 0.8 Btu/hr-ft-°F measures 30 ft by 40 ft with a thickness of 4 inches. The floor has a surface temperature of 70°F and the temperature beneath it is 60°F. What is the heat flux and the heat transfer rate through the floor?

Solution:

Using Equations 2-1 and 2-4:

$$\begin{aligned} \dot{Q}'' &= \frac{\dot{Q}}{A} = k \left(\frac{\Delta T}{\Delta x} \right) \\ &= \left(0.8 \frac{\text{Btu}}{\text{hr-ft-}^\circ\text{F}} \right) \left(\frac{10^\circ\text{F}}{0.333 \text{ ft}} \right) \\ &= 24 \frac{\text{Btu}}{\text{hr-ft}^2} \end{aligned}$$

Using Equation 2-3:

$$\begin{aligned}\dot{Q} &= k A \left(\frac{\Delta T}{\Delta x} \right) = \dot{Q}'' A \\ &= \left(24 \frac{\text{Btu}}{\text{hr-ft}^2} \right) (1200 \text{ ft}^2) \\ &= 28,800 \frac{\text{Btu}}{\text{hr}}\end{aligned}$$

Equivalent Resistance Method

It is possible to compare heat transfer to current flow in electrical circuits. The heat transfer rate may be considered as a current flow and the combination of thermal conductivity, thickness of material, and area as a resistance to this flow. The temperature difference is the potential or driving function for the heat flow, resulting in the Fourier equation being written in a form similar to Ohm's Law of Electrical Circuit Theory. If the thermal resistance term $\Delta x/k$ is written as a resistance term where the resistance is the reciprocal of the thermal conductivity divided by the thickness of the material, the result is the conduction equation being analogous to electrical systems or networks. The electrical analogy may be used to solve complex problems involving both series and parallel thermal resistances. The student is referred to Figure 2, showing the equivalent resistance circuit. A typical conduction problem in its analogous electrical form is given in the following example, where the "electrical" Fourier equation may be written as follows.

$$\dot{Q}'' = \frac{\Delta T}{R_{th}} \quad (2-6)$$

where:

$$\dot{Q}'' = \text{Heat Flux } (\dot{Q}/A) \text{ (Btu/hr-ft}^2\text{)}$$

$$\Delta T = \text{Temperature Difference } (^\circ\text{F)}$$

$$R_{th} = \text{Thermal Resistance } (\Delta x/k) \text{ (hr-ft}^2\text{-}^\circ\text{F/Btu)}$$

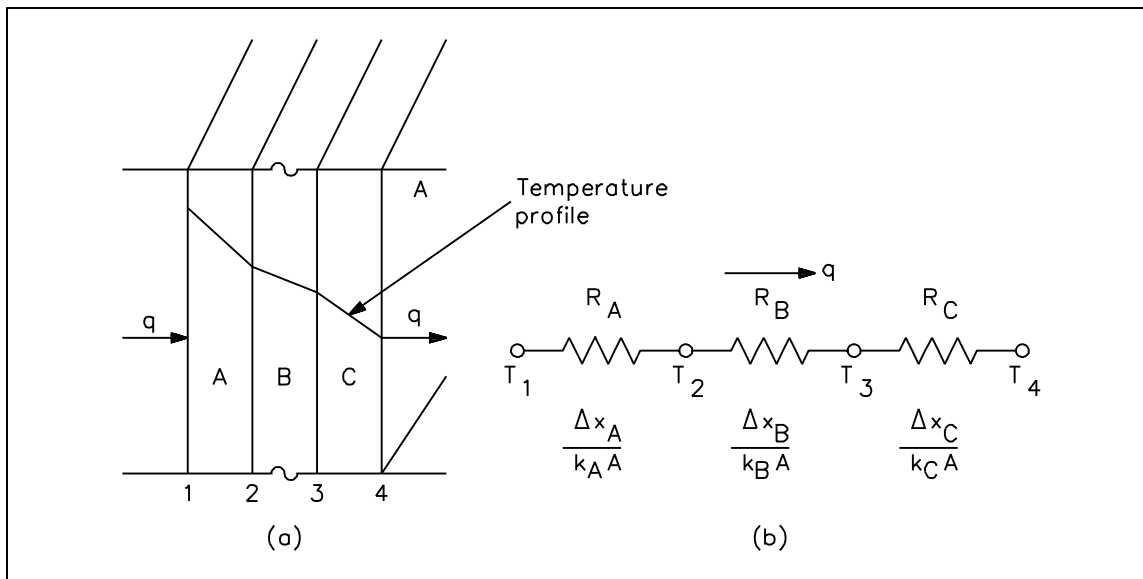

Figure 2 Equivalent Resistance

Electrical Analogy

Example:

A composite protective wall is formed of a 1 in. copper plate, a 1/8 in. layer of asbestos, and a 2 in. layer of fiberglass. The thermal conductivities of the materials in units of Btu/hr-ft-°F are as follows: $k_{Cu} = 240$, $k_{asb} = 0.048$, and $k_{fib} = 0.022$. The overall temperature difference across the wall is 500°F. Calculate the thermal resistance of each layer of the wall and the heat transfer rate per unit area (heat flux) through the composite structure.

Solution:

$$\begin{aligned}
 R_{Cu} &= \frac{\Delta x_{Cu}}{k_{Cu}} & R_{asb} &= \frac{\Delta x_{asb}}{k_{asb}} & R_{fib} &= \frac{\Delta x_{fib}}{k_{fib}} \\
 &= \frac{1 \text{ in} \left(\frac{1 \text{ ft}}{12 \text{ in}} \right)}{240 \frac{\text{Btu}}{\text{hr-ft-}^\circ\text{F}}} & &= \frac{0.125 \text{ in} \left(\frac{1 \text{ ft}}{12 \text{ in}} \right)}{0.048 \frac{\text{Btu}}{\text{hr-ft-}^\circ\text{F}}} & &= \frac{2 \text{ in} \left(\frac{1 \text{ ft}}{12 \text{ in}} \right)}{0.022 \frac{\text{Btu}}{\text{hr-ft-}^\circ\text{F}}} \\
 &= 0.000347 \frac{\text{hr-ft}^2\text{-}^\circ\text{F}}{\text{Btu}} & &= 0.2170 \frac{\text{hr-ft}^2\text{-}^\circ\text{F}}{\text{Btu}} & &= 7.5758 \frac{\text{hr-ft}^2\text{-}^\circ\text{F}}{\text{Btu}}
 \end{aligned}$$

$$\begin{aligned} \frac{\dot{Q}}{A} &= \frac{(T_i - T_o)}{(R_{Cu} + R_{asb} + R_{fib})} \\ &= \frac{500^\circ\text{F}}{(0.000347 + 0.2170 + 7.5758) \frac{\text{hr-ft}^2-\text{°F}}{\text{Btu}}} \\ &= 64.2 \frac{\text{Btu}}{\text{hr-ft}^2} \end{aligned}$$

Conduction-Cylindrical Coordinates

Heat transfer across a rectangular solid is the most direct application of Fourier's law. Heat transfer across a pipe or heat exchanger tube wall is more complicated to evaluate. Across a cylindrical wall, the heat transfer surface area is continually increasing or decreasing. Figure 3 is a cross-sectional view of a pipe constructed of a homogeneous material.

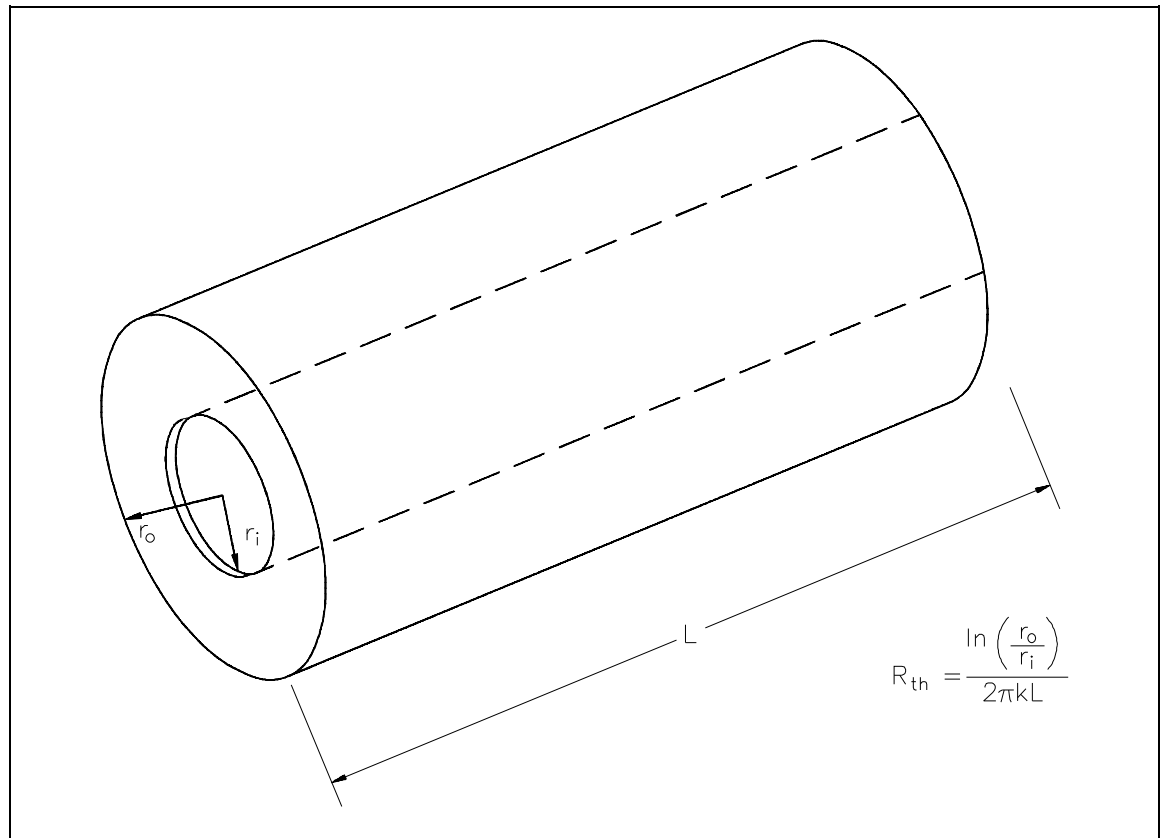

Figure 3 Cross-sectional Surface Area of a Cylindrical Pipe

The surface area (A) for transferring heat through the pipe (neglecting the pipe ends) is directly proportional to the radius (r) of the pipe and the length (L) of the pipe.

$$A = 2\pi rL$$

As the radius increases from the inner wall to the outer wall, the heat transfer area increases.

The development of an equation evaluating heat transfer through an object with cylindrical geometry begins with Fourier's law Equation 2-5.

$$\dot{Q} = k A \left(\frac{\Delta T}{\Delta r} \right)$$

From the discussion above, it is seen that no simple expression for area is accurate. Neither the area of the inner surface nor the area of the outer surface alone can be used in the equation. For a problem involving cylindrical geometry, it is necessary to define a log mean cross-sectional area (A_{lm}).

$$A_{lm} = \frac{A_{outer} - A_{inner}}{\ln \left(\frac{A_{outer}}{A_{inner}} \right)} \quad (2-7)$$

Substituting the expression $2\pi rL$ for area in Equation 2-7 allows the log mean area to be calculated from the inner and outer radius without first calculating the inner and outer area.

$$\begin{aligned} A_{lm} &= \frac{2\pi r_{outer} L - 2\pi r_{inner} L}{\ln \left(\frac{2\pi r_{outer} L}{2\pi r_{inner} L} \right)} \\ &= 2\pi L \left(\frac{r_{outer} - r_{inner}}{\ln \frac{r_{outer}}{r_{inner}}} \right) \end{aligned}$$

This expression for log mean area can be inserted into Equation 2-5, allowing us to calculate the heat transfer rate for cylindrical geometries.

$$\begin{aligned}\dot{Q} &= k A_{\text{lm}} \left(\frac{\Delta T}{\Delta r} \right) \\ &= k \left[2 \pi L \left(\frac{r_o - r_i}{\ln \frac{r_o}{r_i}} \right) \right] \left(\frac{T_o - T_i}{r_o - r_i} \right) \\ \dot{Q} &= \frac{2 \pi k L (\Delta T)}{\ln(r_o/r_i)}\end{aligned}\quad (2-8)$$

where:

L = length of pipe (ft)

r_i = inside pipe radius (ft)

r_o = outside pipe radius (ft)

Example:

A stainless steel pipe with a length of 35 ft has an inner diameter of 0.92 ft and an outer diameter of 1.08 ft. The temperature of the inner surface of the pipe is 122°F and the temperature of the outer surface is 118°F. The thermal conductivity of the stainless steel is 108 Btu/hr-ft-°F.

Calculate the heat transfer rate through the pipe.

Calculate the heat flux at the outer surface of the pipe.

Solution:

$$\begin{aligned}\dot{Q} &= \frac{2 \pi k L (T_h - T_c)}{\ln(r_o/r_i)} \\ &= \frac{6.28 \left(108 \frac{\text{Btu}}{\text{hr-ft-}^\circ\text{F}} \right) (35 \text{ ft}) (122^\circ\text{F} - 118^\circ\text{F})}{\ln \frac{0.54 \text{ ft}}{0.46 \text{ ft}}} \\ &= 5.92 \times 10^5 \frac{\text{Btu}}{\text{hr}}\end{aligned}$$

$$\begin{aligned}
 \dot{Q}'' &= \frac{\dot{Q}}{A} \\
 &= \frac{\dot{Q}}{2 \pi r_o L} \\
 &= \frac{5.92 \times 10^5 \frac{\text{Btu}}{\text{hr}}}{2 (3.14) (0.54 \text{ ft}) (35 \text{ ft})} \\
 &= 4985 \frac{\text{Btu}}{\text{hr-ft}^2}
 \end{aligned}$$

Example:

A 10 ft length of pipe with an inner radius of 1 in and an outer radius of 1.25 in has an outer surface temperature of 250°F. The heat transfer rate is 30,000 Btu/hr. Find the interior surface temperature. Assume $k = 25 \text{ Btu/hr-ft-}^\circ\text{F}$.

Solution:

$$\dot{Q} = \frac{2 \pi k L (T_h - T_c)}{\ln(r_o/r_i)}$$

Solving for T_h :

$$\begin{aligned}
 T_h &= \frac{\dot{Q} \ln(r_o/r_i)}{2 \pi k L} + T_c \\
 &= \frac{\left(30,000 \frac{\text{Btu}}{\text{hr}}\right) \left(\ln \frac{1.25 \text{ in}}{1 \text{ in}}\right)}{2 (3.14) \left(25 \frac{\text{Btu}}{\text{hr-ft-}^\circ\text{F}}\right) (10 \text{ ft})} + 250^\circ\text{F} \\
 &= 254^\circ\text{F}
 \end{aligned}$$

The evaluation of heat transfer through a cylindrical wall can be extended to include a composite body composed of several concentric, cylindrical layers, as shown in Figure 4.

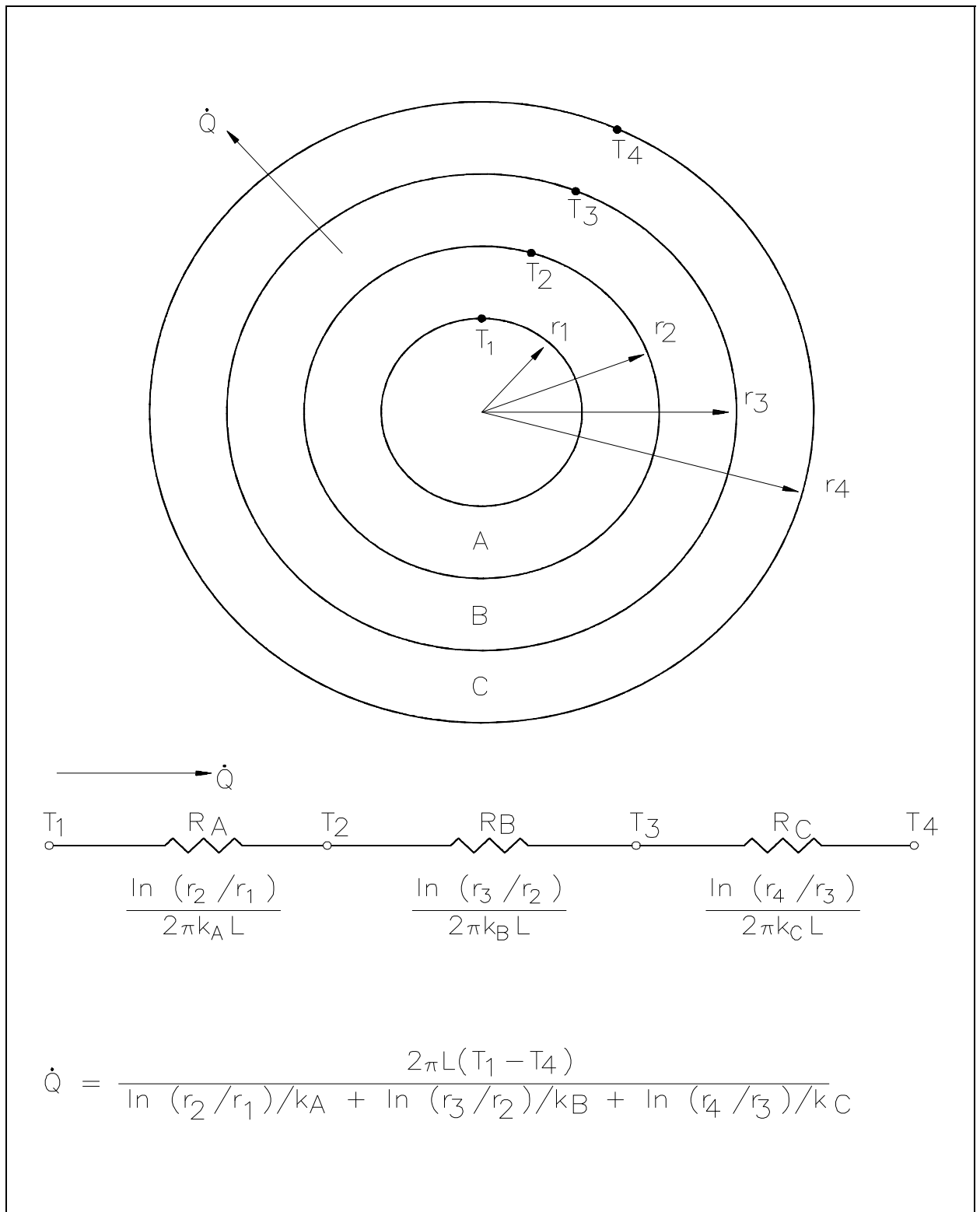

Figure 4 Composite Cylindrical Layers

Example:

A thick-walled nuclear coolant pipe ($k_s = 12.5$ Btu/hr-ft-°F) with 10 in. inside diameter (ID) and 12 in. outside diameter (OD) is covered with a 3 in. layer of asbestos insulation ($k_a = 0.14$ Btu/hr-ft-°F) as shown in Figure 5. If the inside wall temperature of the pipe is maintained at 550°F, calculate the heat loss per foot of length. The outside temperature is 100°F.

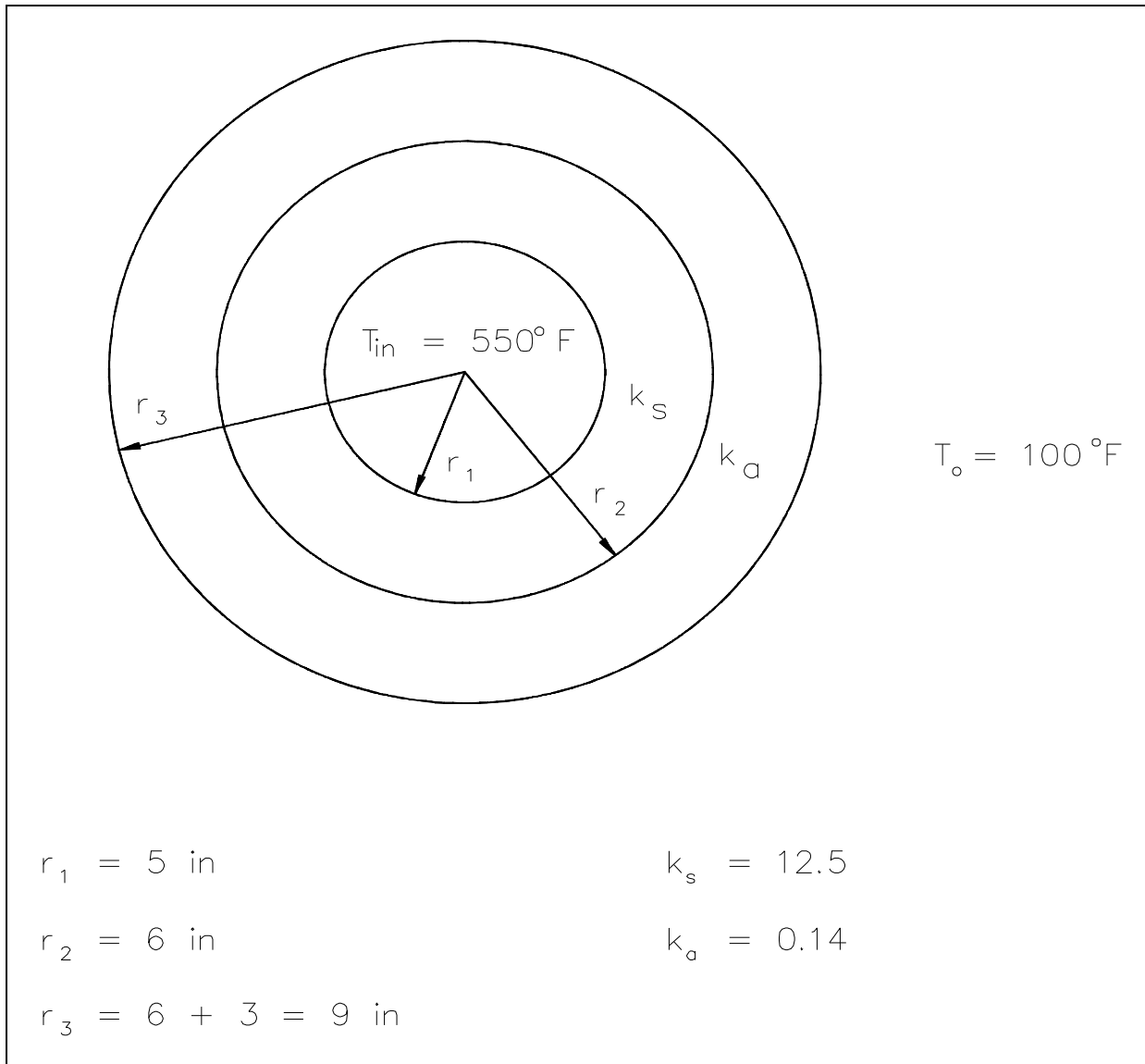

Figure 5 Pipe Insulation Problem

Solution:

$$\begin{aligned} \frac{\dot{Q}}{L} &= \frac{2\pi (T_{in} - T_o)}{\left[\frac{\ln\left(\frac{r_2}{r_1}\right)}{k_s} + \frac{\ln\left(\frac{r_3}{r_2}\right)}{k_a} \right]} \\ &= \frac{2\pi (550^\circ\text{F} - 100^\circ\text{F})}{\left[\frac{\ln\left(\frac{6 \text{ in}}{5 \text{ in}}\right)}{12.5 \frac{\text{Btu}}{\text{hr-ft-}^\circ\text{F}}} + \frac{\ln\left(\frac{9 \text{ in}}{6 \text{ in}}\right)}{0.14 \frac{\text{Btu}}{\text{hr-ft-}^\circ\text{F}}} \right]} \\ &= 971 \frac{\text{Btu}}{\text{hr-ft}} \end{aligned}$$

Summary

The important information in this chapter is summarized below.

Conduction Heat Transfer Summary

- Conduction heat transfer is the transfer of thermal energy by interactions between adjacent molecules of a material.
- Fourier's Law of Conduction can be used to solve for rectangular and cylindrical coordinate problems.
- Heat flux (\dot{Q}'') is the heat transfer rate (\dot{Q}) divided by the area (A).
- Heat conductance problems can be solved using equivalent resistance formulas analogous to electrical circuit problems.

CONVECTION HEAT TRANSFER

Heat transfer by the motion and mixing of the molecules of a liquid or gas is called convection.

EO 1.9 Given the formula for heat transfer and the operating conditions of the system, **CALCULATE** the rate of heat transfer by convection.

Convection

Convection involves the transfer of heat by the motion and mixing of "macroscopic" portions of a fluid (that is, the flow of a fluid past a solid boundary). The term natural convection is used if this motion and mixing is caused by density variations resulting from temperature differences within the fluid. The term forced convection is used if this motion and mixing is caused by an outside force, such as a pump. The transfer of heat from a hot water radiator to a room is an example of heat transfer by natural convection. The transfer of heat from the surface of a heat exchanger to the bulk of a fluid being pumped through the heat exchanger is an example of forced convection.

Heat transfer by convection is more difficult to analyze than heat transfer by conduction because no single property of the heat transfer medium, such as thermal conductivity, can be defined to describe the mechanism. Heat transfer by convection varies from situation to situation (upon the fluid flow conditions), and it is frequently coupled with the mode of fluid flow. In practice, analysis of heat transfer by convection is treated empirically (by direct observation).

Convection heat transfer is treated empirically because of the factors that affect the stagnant film thickness:

- Fluid velocity
- Fluid viscosity
- Heat flux
- Surface roughness
- Type of flow (single-phase/two-phase)

Convection involves the transfer of heat between a surface at a given temperature (T_s) and fluid at a bulk temperature (T_b). The exact definition of the bulk temperature (T_b) varies depending on the details of the situation. For flow adjacent to a hot or cold surface, T_b is the temperature of the fluid "far" from the surface. For boiling or condensation, T_b is the saturation temperature of the fluid. For flow in a pipe, T_b is the average temperature measured at a particular cross-section of the pipe.

The basic relationship for heat transfer by convection has the same form as that for heat transfer by conduction:

$$\dot{Q} = h A \Delta T \quad (2-9)$$

where:

$$\dot{Q} = \text{rate of heat transfer (Btu/hr)}$$

$$h = \text{convective heat transfer coefficient (Btu/hr-ft}^2\text{-}^\circ\text{F)}$$

$$A = \text{surface area for heat transfer (ft}^2\text{)}$$

$$\Delta T = \text{temperature difference (}^\circ\text{F)}$$

The convective heat transfer coefficient (h) is dependent upon the physical properties of the fluid and the physical situation. Typically, the convective heat transfer coefficient for laminar flow is relatively low compared to the convective heat transfer coefficient for turbulent flow. This is due to turbulent flow having a thinner stagnant fluid film layer on the heat transfer surface. Values of h have been measured and tabulated for the commonly encountered fluids and flow situations occurring during heat transfer by convection.

Example:

A 22 foot uninsulated steam line crosses a room. The outer diameter of the steam line is 18 in. and the outer surface temperature is 280°F. The convective heat transfer coefficient for the air is 18 Btu/hr-ft²-°F. Calculate the heat transfer rate from the pipe into the room if the room temperature is 72°F.

Solution:

$$\begin{aligned} \dot{Q} &= h A \Delta T \\ &= h (2 \pi r L) \Delta T \\ &= \left(18 \frac{\text{Btu}}{\text{hr-ft}^2\text{-}^\circ\text{F}} \right) (2 (3.14) (0.75 \text{ ft}) (22 \text{ ft})) (280^\circ\text{F} - 72^\circ\text{F}) \\ &= 3.88 \times 10^5 \frac{\text{Btu}}{\text{hr}} \end{aligned}$$

Many applications involving convective heat transfer take place within pipes, tubes, or some similar cylindrical device. In such circumstances, the surface area of heat transfer normally given in the convection equation ($\dot{Q} = h A \Delta T$) varies as heat passes through the cylinder. In addition, the temperature difference existing between the inside and the outside of the pipe, as well as the temperature differences along the pipe, necessitates the use of some average temperature value in order to analyze the problem. This average temperature difference is called the log mean temperature difference (LMTD), described earlier.

It is the temperature difference at one end of the heat exchanger minus the temperature difference at the other end of the heat exchanger, divided by the natural logarithm of the ratio of these two temperature differences. The above definition for LMTD involves two important assumptions: (1) the fluid specific heats do not vary significantly with temperature, and (2) the convection heat transfer coefficients are relatively constant throughout the heat exchanger.

Overall Heat Transfer Coefficient

Many of the heat transfer processes encountered in nuclear facilities involve a combination of both conduction and convection. For example, heat transfer in a steam generator involves convection from the bulk of the reactor coolant to the steam generator inner tube surface, conduction through the tube wall, and convection from the outer tube surface to the secondary side fluid.

In cases of combined heat transfer for a heat exchanger, there are two values for h . There is the convective heat transfer coefficient (h) for the fluid film inside the tubes and a convective heat transfer coefficient for the fluid film outside the tubes. The thermal conductivity (k) and thickness (Δx) of the tube wall must also be accounted for. An additional term (U_o), called the overall heat transfer coefficient, must be used instead. It is common practice to relate the total rate of heat transfer (\dot{Q}) to the cross-sectional area for heat transfer (A_o) and the overall heat transfer coefficient (U_o). The relationship of the overall heat transfer coefficient to the individual conduction and convection terms is shown in Figure 6.

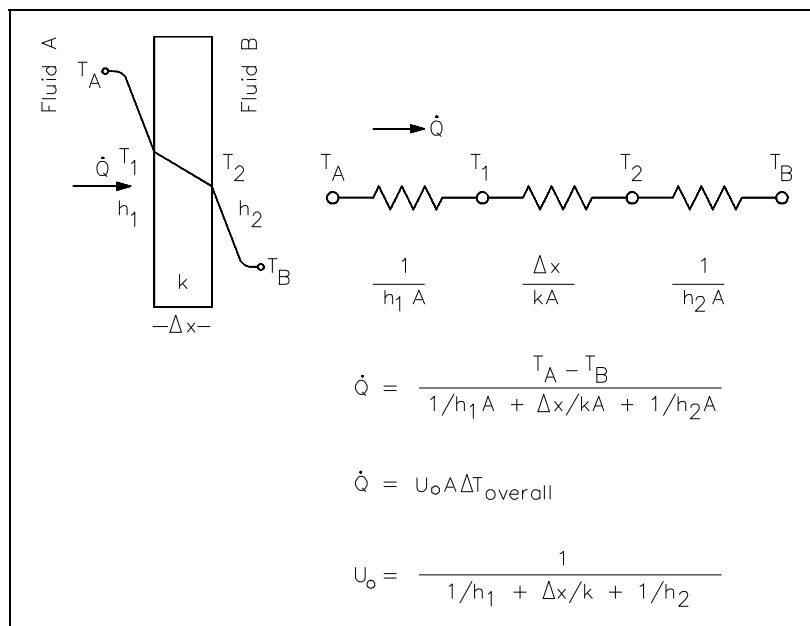

Figure 6 Overall Heat Transfer Coefficient

Recalling Equation 2-3:

$$\dot{Q} = U_o A_o \Delta T_o$$

where U_o is defined in Figure 6.

An example of this concept applied to cylindrical geometry is illustrated by Figure 7, which shows a typical combined heat transfer situation.

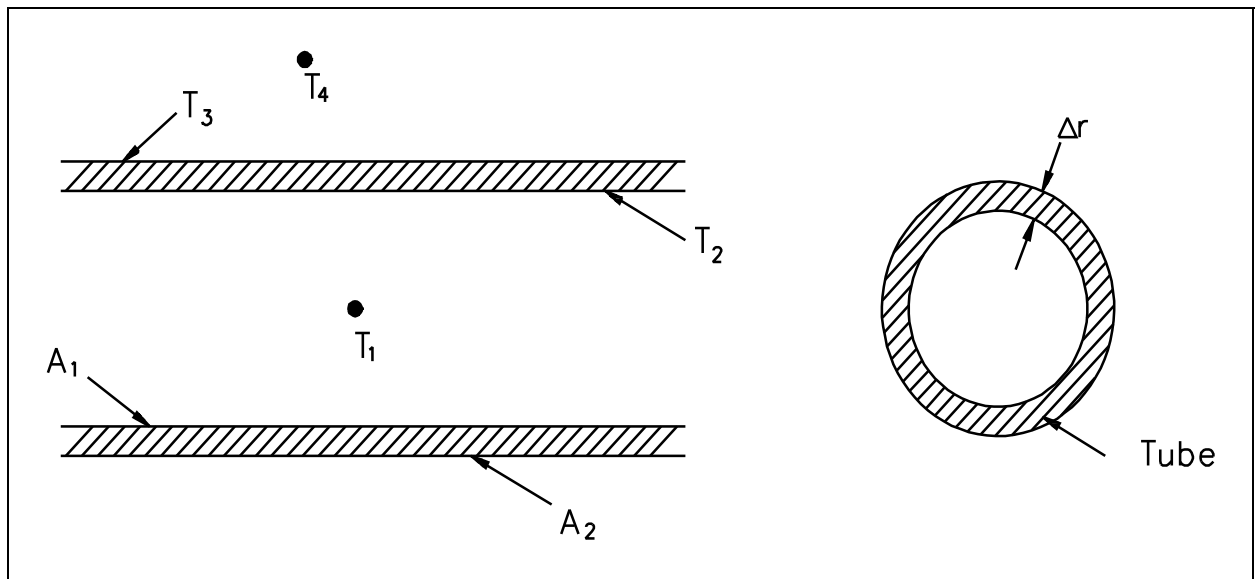

Figure 7 Combined Heat Transfer

Using the figure representing flow in a pipe, heat transfer by convection occurs between temperatures T_1 and T_2 ; heat transfer by conduction occurs between temperatures T_2 and T_3 ; and heat transfer occurs by convection between temperatures T_3 and T_4 . Thus, there are three processes involved. Each has an associated heat transfer coefficient, cross-sectional area for heat transfer, and temperature difference. The basic relationships for these three processes can be expressed using Equations 2-5 and 2-9.

$$\dot{Q} = h_1 A_1 (T_1 - T_2)$$

$$\dot{Q} = \frac{k}{\Delta r} A_{lm} (T_2 - T_3)$$

$$\dot{Q} = h_2 A_2 (T_3 - T_4)$$

ΔT_o can be expressed as the sum of the ΔT of the three individual processes.

$$\Delta T_o = (T_1 - T_2) + (T_2 - T_3) + (T_3 - T_4)$$

If the basic relationship for each process is solved for its associated temperature difference and substituted into the expression for ΔT_o above, the following relationship results.

$$\Delta T_o = \dot{Q} \left(\frac{1}{h_1 A_1} + \frac{\Delta r}{k A_{lm}} + \frac{1}{h_2 A_2} \right)$$

This relationship can be modified by selecting a reference cross-sectional area A_o .

$$\Delta T_o = \frac{\dot{Q}}{A_o} \left(\frac{A_o}{h_1 A_1} + \frac{\Delta r A_o}{k A_{lm}} + \frac{A_o}{h_2 A_2} \right)$$

Solving for \dot{Q} results in an equation in the form $\dot{Q} = U_o A_o \Delta T_o$.

$$\dot{Q} = \frac{1}{\left(\frac{A_o}{h_1 A_1} + \frac{\Delta r A_o}{k A_{lm}} + \frac{A_o}{h_2 A_2} \right)} A_o \Delta T_o$$

where:

$$U_o = \frac{1}{\left(\frac{A_o}{h_1 A_1} + \frac{\Delta r A_o}{k A_{lm}} + \frac{A_o}{h_2 A_2} \right)} \quad (2-10)$$

Equation 2-10 for the overall heat transfer coefficient in cylindrical geometry is relatively difficult to work with. The equation can be simplified without losing much accuracy if the tube that is being analyzed is thin-walled, that is the tube wall thickness is small compared to the tube diameter. For a thin-walled tube, the inner surface area (A_1), outer surface area (A_2), and log mean surface area (A_{lm}), are all very close to being equal. Assuming that A_1 , A_2 , and A_{lm} are equal to each other and also equal to A_o allows us to cancel out all the area terms in the denominator of Equation 2-11.

This results in a much simpler expression that is similar to the one developed for a flat plate heat exchanger in Figure 6.

$$U_o = \frac{1}{\frac{1}{h_1} + \frac{\Delta r}{k} + \frac{1}{h_2}} \quad (2-11)$$

The convection heat transfer process is strongly dependent upon the properties of the fluid being considered. Correspondingly, the convective heat transfer coefficient (h), the overall coefficient (U_o), and the other fluid properties may vary substantially for the fluid if it experiences a large temperature change during its path through the convective heat transfer device. This is especially true if the fluid's properties are strongly temperature dependent. Under such circumstances, the temperature at which the properties are "looked-up" must be some type of average value, rather than using either the inlet or outlet temperature value.

For internal flow, the bulk or average value of temperature is obtained analytically through the use of conservation of energy. For external flow, an average film temperature is normally calculated, which is an average of the free stream temperature and the solid surface temperature. In any case, an average value of temperature is used to obtain the fluid properties to be used in the heat transfer problem. The following example shows the use of such principles by solving a convective heat transfer problem in which the bulk temperature is calculated.

Convection Heat Transfer

Example:

A flat wall is exposed to the environment. The wall is covered with a layer of insulation 1 in. thick whose thermal conductivity is 0.8 Btu/hr-ft-°F. The temperature of the wall on the inside of the insulation is 600°F. The wall loses heat to the environment by convection on the surface of the insulation. The average value of the convection heat transfer coefficient on the insulation surface is 950 Btu/hr-ft²-°F. Compute the bulk temperature of the environment (T_b) if the outer surface of the insulation does not exceed 105°F.

Solution:

- a. Find heat flux (\dot{Q}'') through the insulation.

$$\dot{Q} = k A \left(\frac{\Delta T}{\Delta x} \right)$$

$$\frac{\dot{Q}}{A} = 0.8 \frac{\text{Btu}}{\text{hr-ft-}^\circ\text{F}} \left(\frac{600^\circ\text{F} - 105^\circ\text{F}}{1 \text{ in } \frac{1 \text{ ft}}{12 \text{ in}}} \right)$$

$$= 4752 \frac{\text{Btu}}{\text{hr-ft}^2}$$

- b. Find the bulk temperature of the environment.

$$\dot{Q} = h A (T_{\text{ins}} - T_b)$$

$$(T_{\text{ins}} - T_b) = \frac{\dot{Q}}{h A}$$

$$T_b = T_{\text{ins}} - \frac{\dot{Q}''}{h}$$

$$T_b = 105^\circ\text{F} - \frac{4752 \frac{\text{Btu}}{\text{hr-ft}^2}}{950 \frac{\text{Btu}}{\text{hr-ft}^2-^\circ\text{F}}}$$

$$T_b = 100^\circ\text{F}$$

Summary

The important information in this chapter is summarized below.

Convection Heat Transfer Summary

- Convection heat transfer is the transfer of thermal energy by the mixing and motion of a fluid or gas.
- Whether convection is natural or forced is determined by how the medium is placed into motion.
- When both convection and conduction heat transfer occurs, the overall heat transfer coefficient must be used to solve problems.
- The heat transfer equation for convection heat transfer is $\dot{Q} = hA\Delta T$.

RADIANT HEAT TRANSFER

Radiant heat transfer is thermal energy transferred by means of electromagnetic waves or particles.

- EO 1.10 DESCRIBE how the following terms relate to radiant heat transfer:**
- a. Black body radiation**
 - b. Emissivity**
 - c. Radiation configuration factor**
-

Thermal Radiation

Radiant heat transfer involves the transfer of heat by electromagnetic radiation that arises due to the temperature of a body. Most energy of this type is in the infra-red region of the electromagnetic spectrum although some of it is in the visible region. The term thermal radiation is frequently used to distinguish this form of electromagnetic radiation from other forms, such as radio waves, x-rays, or gamma rays. The transfer of heat from a fireplace across a room in the line of sight is an example of radiant heat transfer.

Radiant heat transfer does not need a medium, such as air or metal, to take place. Any material that has a temperature above absolute zero gives off some radiant energy. When a cloud covers the sun, both its heat and light diminish. This is one of the most familiar examples of heat transfer by thermal radiation.

Black Body Radiation

A body that emits the maximum amount of heat for its absolute temperature is called a black body. Radiant heat transfer rate from a black body to its surroundings can be expressed by the following equation.

$$\dot{Q} = \sigma AT^4 \quad (2-12)$$

where:

\dot{Q} = heat transfer rate (Btu/hr)

σ = Stefan-Boltzman constant (0.174 Btu/hr-ft²-°R⁴)

A = surface area (ft²)

T = temperature (°R)

Two black bodies that radiate toward each other have a net heat flux between them. The net flow rate of heat between them is given by an adaptation of Equation 2-12.

$$\dot{Q} = \sigma A(T_1^4 - T_2^4)$$

where:

A = surface area of the first body (ft²)

T₁ = temperature of the first body (°R)

T₂ = temperature of the second body (°R)

All bodies above absolute zero temperature radiate some heat. The sun and earth both radiate heat toward each other. This seems to violate the Second Law of Thermodynamics, which states that heat cannot flow from a cold body to a hot body. The paradox is resolved by the fact that each body must be in direct line of sight of the other to receive radiation from it. Therefore, whenever the cool body is radiating heat to the hot body, the hot body must also be radiating heat to the cool body. Since the hot body radiates more heat (due to its higher temperature) than the cold body, the net flow of heat is from hot to cold, and the second law is still satisfied.

Emissivity

Real objects do not radiate as much heat as a perfect black body. They radiate less heat than a black body and are called gray bodies. To take into account the fact that real objects are gray bodies, Equation 2-12 is modified to be of the following form.

$$\dot{Q} = \varepsilon \sigma A T^4$$

where:

ε = emissivity of the gray body (dimensionless)

Emissivity is simply a factor by which we multiply the black body heat transfer to take into account that the black body is the ideal case. Emissivity is a dimensionless number and has a maximum value of 1.0.

Radiation Configuration Factor

Radiative heat transfer rate between two gray bodies can be calculated by the equation stated below.

$$\dot{Q} = f_a f_e \sigma A(T_1^4 - T_2^4)$$

where:

f_a = is the shape factor, which depends on the spatial arrangement of the two objects (dimensionless)

f_e = is the emissivity factor, which depends on the emissivities of both objects (dimensionless)

The two separate terms f_a and f_e can be combined and given the symbol f . The heat flow between two gray bodies can now be determined by the following equation:

$$\dot{Q} = f\sigma A(T_1^4 - T_2^4) \quad (2-13)$$

The symbol (f) is a dimensionless factor sometimes called the *radiation configuration factor*, which takes into account the emissivity of both bodies and their relative geometry. The radiation configuration factor is usually found in a text book for the given situation. Once the configuration factor is obtained, the overall net heat flux can be determined. Radiant heat flux should only be included in a problem when it is greater than 20% of the problem.

Example:

Calculate the radiant heat between the floor (15 ft x 15 ft) of a furnace and the roof, if the two are located 10 ft apart. The floor and roof temperatures are 2000°F and 600°F, respectively. Assume that the floor and the roof have black surfaces.

Solution:

$$A_1 = A_2 = (15 \text{ ft}) (15 \text{ ft}) = 225 \text{ ft}^2$$

$$T_1 = 2000^\circ\text{F} + 460 = 2460^\circ\text{R}$$

$$T_2 = 600^\circ\text{F} + 460 = 1060^\circ\text{R}$$

Tables from a reference book, or supplied by the instructor, give:

$$f_{1-2} = f_{2-1} = 0.31$$

$$Q_{1-2} = \sigma A f (T_1^4 - T_2^4)$$

$$= (0.174 \frac{\text{Btu}}{\text{hr-ft}^2-\text{R}^4}) (225 \text{ ft}^2) (0.31) [(2460^\circ\text{R})^4 - (1060^\circ\text{R})^4]$$

$$= 4.29 \times 10^{14} \text{ Btu/hr}$$

Summary

The important information in this chapter is summarized below.

Radiant Heat Transfer Summary

- Black body radiation is the maximum amount of heat that can be transferred from an ideal object.
- Emissivity is a measure of the departure of a body from the ideal black body.
- Radiation configuration factor takes into account the emittance and relative geometry of two objects.